

Riverside Condominiums Phase 1

Address: 1025 Opal Dr.
Units: A - H

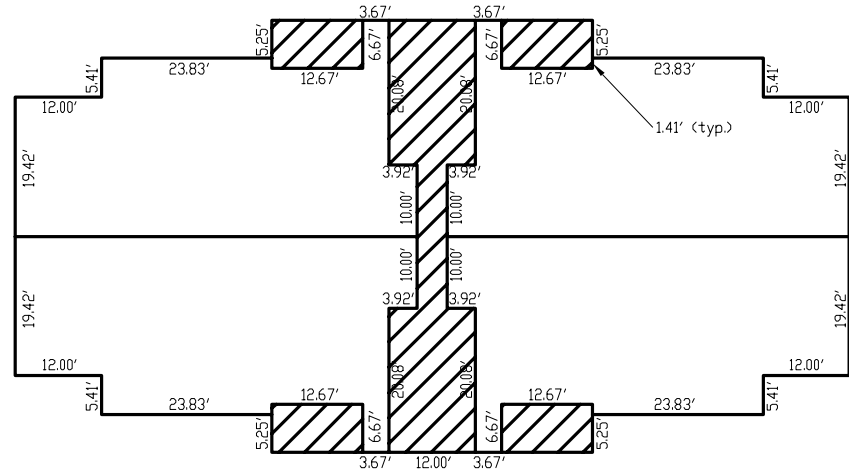
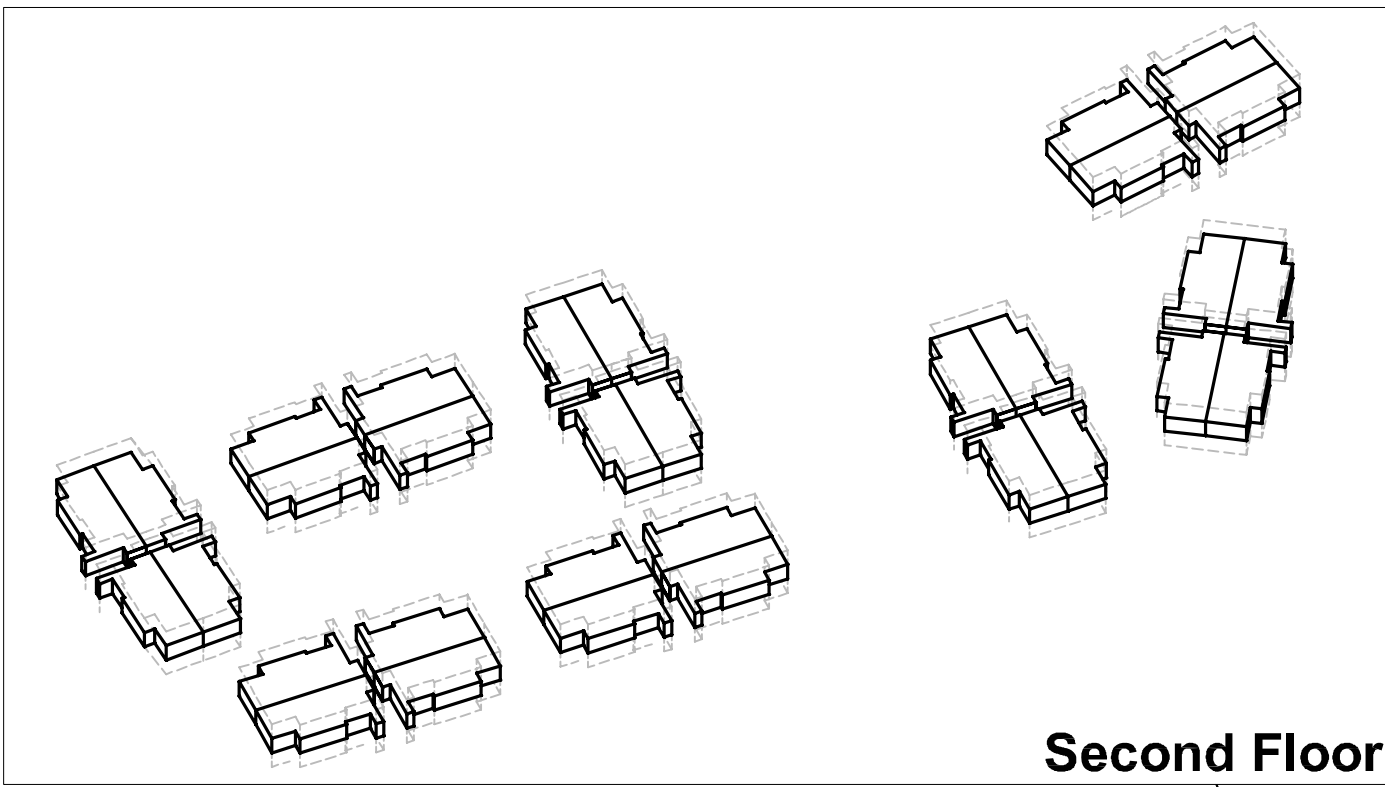

LIMITED COMMON AREA

Typical Building

811.21'

①
6.772 Ac.
Lot 2A

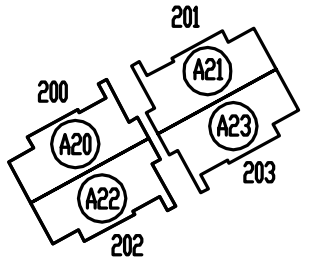

434.89'

②
2.787 Ac.
Lot 2B

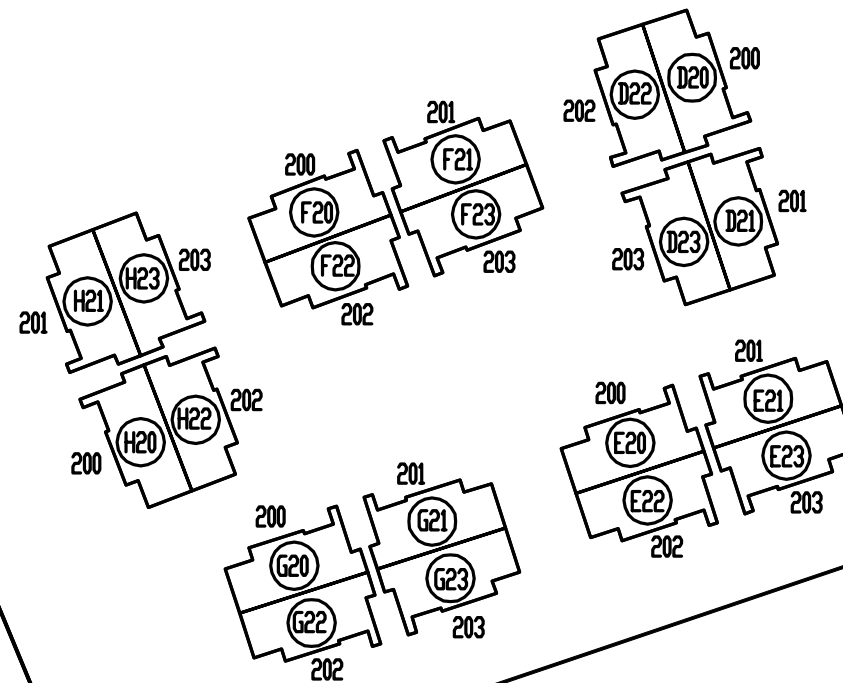

319.99'

12th Street

Opal Drive

Opal Drive

355.87'

50.00'

100.00'

345.49'

20.00'

355.07'

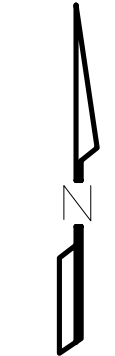

scale 1"=80'